



GATE VALVES - CAST STEEL GATE VALVES



Gate valves are most efficient On-Off valves with bi-directional flow. It houses a wedge sliding in a flow passageway in order to start or stop the flow or process medium. One of the best characteristics of gate valves is its straight and un-obstructed passage in the “full open” position. This happens when the wedge is lifted entirely out of the passageway. Therefore, gate valves are characterized by a minimum pressure drop and flow turbulence when in operation. Since, gate valves are good for applications with these two factors, gate valves are not recommended for applications for control and modulation. These are purely designed and standardized for on/off applications.



DESIGN STANDARD	
Bolted Bonnet Gate Valve	API 600/ISO 10434 & ASME B16.34
Pressure Seal Gate Valve (Long & Short pattern)	ASME B16.34
API 603 Gate Valve	API 603
Through Conduit Gate Valve	API 6D
Cryogenic Gate	API 600 / BS 1873 & BS 6364
Face to Face / End to End Dimensions	ASME B16.10 / ISO 5752
End Flanged dimensions	ASME B16.5 / ISO 7005-1, ASME B16.47-A&B, MSS SP-44 & API 605
Butt-weld End dimensions	ASME B16.25
Valve inspection & testing	API 600 / ISO 10434 & ISO 5208, EN 17266
Pressure - Temperature rating	ASME B16.34

TEST / INSPECTION	METHOD	ACCEPTANCE CRITERIA
Visual Inspection		MSS SP-55
Marking		MSS SP-25 & ISO5208
Dimensional Inspection		Applicable valve
Chemical Analysis	ASTM E350	Applicable Standard
Mechanical Properties	ASTM A370	Applicable Standard
Liquid Penetrant Inspection	ASTM A165	ASME B16.34
Magnetic Particle Inspection	ASTM E709	ASME B16.34
Radiographic Inspection	ASME B16.34	ASME B16.34
Ultrasonic Inspection	ASTM A388	ASME B16.34
Pressure Testing	API 598 / ISO 5208	API 598 / ISO 5208

API 600 TRIM CHART			
API 600TRIM N ^o	Nominal TRIM	Stem / Backseat	Seating Surface Body / Wedge
1	F6	13Cr	13Cr
2	304	18Cr-8Ni	18Cr-8Ni
3	F310	25Cr-20Ni	25Cr-20Ni
4	Hard F6	13Cr	Hard 13Cr
5	Hardfaced	13Cr	Co-Cr A
5A	Hardfaced	13Cr	Ni-Cr
6	F6 and Cu-Ni	13Cr	13Cr and Cu-Ni
7	F6 and Hard F6	13Cr	13Cr and Hard 13Cr
8	F6 and Hardfaced	13Cr	13Cr and Co-Cr A
8A	F6 and Hardfaced	13Cr	13Cr and Ni-Cr
9	Monel	Ni-Cu Alloy	Ni-Cu Alloy
10	316	18Cr-8Ni-Mo	18Cr-8Ni-Mo
11	Monel and Hardfaced	Ni-Cu Alloy	Ni-Cu Alloy and Trim 5 or 5A
12	316 and Hardfaced	18Cr-8Ni-Mo	18Cr-8Ni-Mo and Trim 5 or 5A
13	Alloy 20	19Cr-29Ni	19Cr-29Ni
14	Alloy 20 and Hardfaced	19Cr-29Ni	19Cr-29Ni and Trim 5 or 5A
15	Hardfaced	18Cr-8Ni	Co-Cr A
16	Hardfaced	18Cr-8Ni-Mo	Co-Cr A
17	Hardfaced	18Cr-10Ni-Cb	Co-Cr A
18	Hardfaced	19Cr-29Ni	Co-Cr A





GATE VALVES - CAST STEEL GATE VALVES 150# & 300#

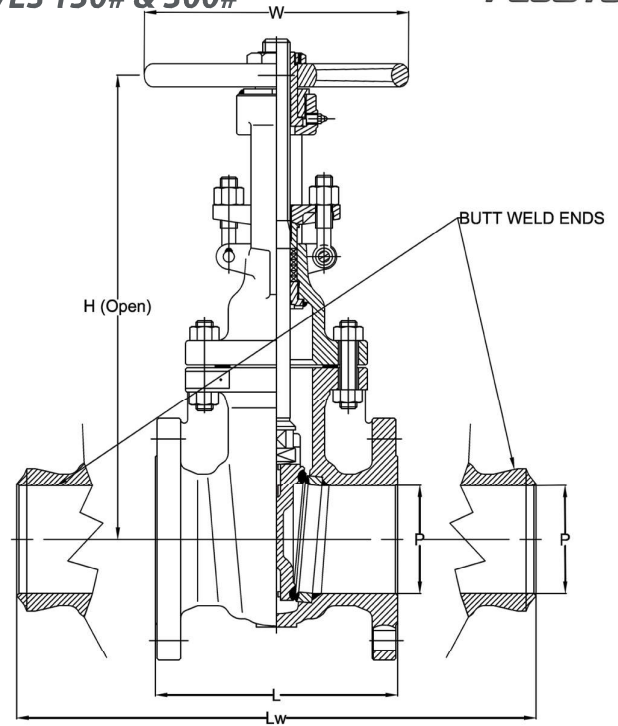

150#					
DN (inch)	L	Lw	H	W	WEIGHT (Kg) Approx
50 (2")	178	216	386	200	17
65 (2½")	190	241	435	200	27
80 (3")	203	282,5	483	250	33
100 (4")	229	305	587	250	48
125 (5")	254	381	673	300	65
150 (6")	267	403	767	300	78
200 (8")	292	419	955	350	120
250 (10")	330	457	1146	450	176
300 (12")	356	502	1328	500	260
350 (14")	381	572	1519	460*	380 (*)
400 (16")	406	610	1721	460 (*)	530 (*)
450 (18")	432	660	1900	460 (*)	620 (*)
500 (20")	457	711	2116	610 (*)	810 (*)
550 (22")	483	762	2315	610 (*)	1050 (*)
600 (24")	508	813	2480	610 (*)	1150 (*)
650 (26")	559	-	2700	610 (*)	1380 (*)
700 (28")	610	-	2975	610 (*)	1980 (*)
750 (30")	610	-	3102	610 (*)	2200 (*)
900 (36")	711	-	3668	710 (*)	2800 (*)

(Code-SS)

300#					
DN (inch)	L	Lw	A	H	WEIGHT (Kg) Approx
50 (2")	216	216	417	200	24
65 (2½")	241	241	460	250	35
80 (3")	283	283	526	250	49
100 (4")	305	305	650	250	69
125 (5")	381	381	694	300	92
150 (6")	403	403	824	350	130
200 (8")	419	419	987	450	208
250 (10")	457	457	1192	500	333
300 (12")	502	502	1431	560	536
350 (14")	762	762	1559	460 (*)	699 (*)
400 (16")	838	838	1758	460 (*)	1010 (*)
450 (18")	914	914	1942	610 (*)	1205 (*)
500 (20")	991	991	2145	610 (*)	1720 (*)
550 (22")	1092	1092	2340	610 (*)	1920 (*)
600 (24")	1143	1143	2526	610 (*)	2580 (*)

(Code-SS)





GATE VALVES - CAST STEEL GATE VALVES - 600#, 900#, 1500# & 2500# FLOWTORQ

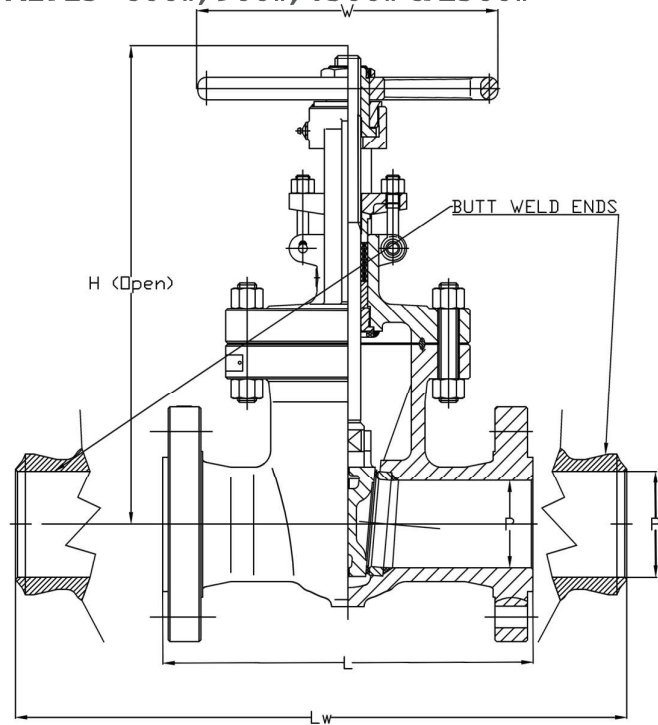

600GTV					
DN (inch)	L	Lw	A	H	WEIGHT (Kg) Approx
50 (2")	292	292	427	250	33
65 (2½")	330	330	473	250	58
80 (3")	356	356	538	300	63
100 (4")	432	432	657	350	131
125 (5")	508	508	770	400	182
150 (6")	559	559	872	500	253
200 (8")	660	660	1101	560	413
250 (10")	787	787	1279	720	623
300 (12")	838	838	1486	610 (*)	784 (*)
350 (14")	889	889	1643	610 (*)	1288 (*)
400 (16")	991	991	1798	610 (*)	1820 (*)
450 (18")	1092	1092	2101	610 (*)	2150 (*)
500 (20")	1194	1194	2259	710 (*)	2540 (*)
550 (22")	1295	1295	2405	760 (*)	2800 (*)
600 (24")	1397	1397	2545	760 (*)	3350 (*)

(Code-SS)

900GTV					
DN (inch)	L	Lw	A	H	WEIGHT (Kg) Approx
50 (2")	368	368	547	300	90
65 (2½")	419	419	700	350	110
80 (3")	381	381	648	400	123
100 (4")	457	457	729	450	148
125 (5")	559	559	890	500	280
150 (6")	610	610	1041	560	420
200 (8")	737	737	1260	460 (*)	650 (*)
250 (10")	838	838	1590	610 (*)	1160 (*)
300 (12")	965	965	1795	610 (*)	1700 (*)
350 (14")	1029	1029	2025	760 (*)	2300 (*)
400 (16")	1130	1130	2170	760 (*)	2750 (*)
450 (18")	1219	1219	2345	760 (*)	3120 (*)
500 (20")	1321	1321	2610	760 (*)	3550 (*)

(Code-SS)

1500GTV					
DN (inch)	L	Lw	A	H	WEIGHT (Kg) Approx
50 (2")	368	368	574	350	117
65 (2½")	419	419	700	400	175
80 (3")	470	470	806	450	240
100 (4")	546	546	887	560	337
125 (5")	673	673	995	560	485
150 (6")	705	705	1079	305 (*)	680
200 (8")	832	832	1370	610 (*)	1228 (*)
250 (10")	991	991	1520	760 (*)	2218 (*)
300 (12")	1130	1130	1651	760 (*)	3260 (*)
350 (14")	1257	1257	1825	760 (*)	3990 (*)
400 (16")	1384	1384	1995	760 (*)	5420 (*)

(Code-SS)

2500GTV					
DN (inch)	L	Lw	A	H	WEIGHT (Kg) Approx
50 (2")	451	451	595	400	155
65 (2½")	508	508	675	450	215
80 (3")	578	578	750	560	285
100 (4")	673	673	805	610	405
125 (5")	794	794	1010	610	715
150 (6")	914	914	1200	460 (*)	1050 (*)
200 (8")	1022	1022	1346	610 (*)	1700 (*)
250 (10")	1270	1270	1500	760 (*)	2950 (*)
300 (12")	1422	1422	1700	760 (*)	4120 (*)
350 (14")	1575	1575	1950	760 (*)	5790 (*)

(Code-SS)



GATE VALVES - PRESSURE SEALED GATE VALVES



FLOWTORQ Pressure Seal Gate Valves are best suited for high pressure applications like steam, liquid, catalytic reformers, hydrocrackers and other tough services. For High pressure, High temperature applications, Pressure seal gate valves continue to cater a wide range of industries with a safest, leakage free, pressure holding service. In opposition to bolted-bonnet valves, internal pressure applied to a pressure seal valve forces the sealing parts into more tighter contact—the higher the internal pressure, the tighter the seal. Afterwards the line pressure provides extra force to seal the gasket. Thus, as line pressure increases, the chances for leakage through the body-bonnet joint is less.

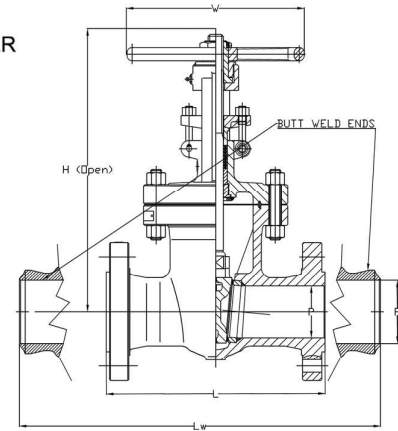
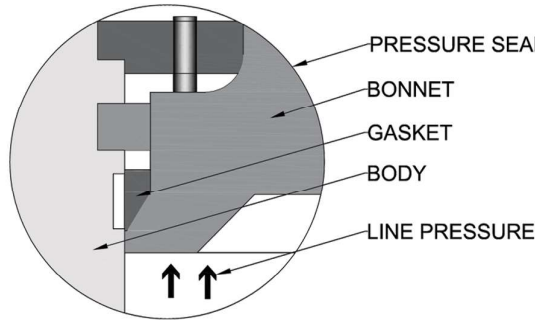

900GTV					
DN (inch)	L	Lw	A	H	WEIGHT (Kg) Approx
50 (2")	368	368	547	300	90
65 (2½")	419	419	700	350	110
80 (3")	381	381	648	400	123
100 (4")	457	457	729	450	148
125 (5")	559	559	890	500	280
150 (6")	610	610	1041	560	420
200 (8")	737	737	1260	460 (*)	650 (*)
250 (10")	838	838	1590	610 (*)	1160 (*)
300 (12")	965	965	1795	610 (*)	1700 (*)
350 (14")	1029	1029	2025	760 (*)	2300 (*)
400 (16")	1130	1130	2170	760 (*)	2750 (*)
450 (18")	1219	1219	2345	760 (*)	3120 (*)
500 (20")	1321	1321	2610	760 (*)	3550 (*)

(Code-SS)

1500GTV					
DN (inch)	L	Lw	A	H	WEIGHT (Kg) Approx
50 (2")	368	368	574	350	117
65 (2½")	419	419	700	400	175
80 (3")	470	470	806	450	240
100 (4")	546	546	887	560	337
125 (5")	673	673	995	560	485
150 (6")	705	705	1079	305 (*)	680
200 (8")	832	832	1370	610 (*)	1228 (*)
250 (10")	991	991	1520	760 (*)	2218 (*)
300 (12")	1130	1130	1651	760 (*)	3260 (*)
350 (14")	1257	1257	1825	760 (*)	3990 (*)
400 (16")	1384	1384	1995	760 (*)	5420 (*)

(Code-SS)

2500GTV					
DN (inch)	L	Lw	A	H	WEIGHT (Kg) Approx
50 (2")	451	451	595	400	155
65 (2½")	508	508	675	450	215
80 (3")	578	578	750	560	285
100 (4")	673	673	805	610	405
125 (5")	794	794	1010	610	715
150 (6")	914	914	1200	460 (*)	1050 (*)
200 (8")	1022	1022	1346	610 (*)	1700 (*)
250 (10")	1270	1270	1500	760 (*)	2950 (*)
300 (12")	1422	1422	1700	760 (*)	4120 (*)
350 (14")	1575	1575	1950	760 (*)	5790 (*)

(Code-SS)





GATE VALVES - FORGED STEEL GATE VALVES - 800#, 1500# & 2500#



Socket Weld / Threaded Ends

FLOWTORQ Forged Steel gate valves are manufactured with highest quality steel forgings. Forged form valves are used widely in high pressure applications in smaller sizes like 1/4" to 2" in ratings upto 4500#. Usually are manufactured in socket welded, threaded and welded flanged types as per client application requirement.

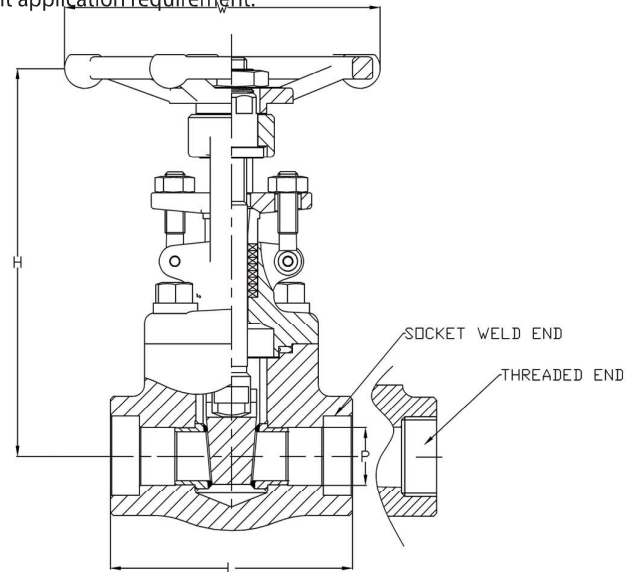

Design and Manufacturing Standard	API602
Testing Standard	API598
Face to Face Standard	ANSI B 16.11 / ANSI B 16.5
End Connections	NPT, Socket Weld / Flanged

800# - Socket Weld					
Size	1/2"	3/4"	1"	1 1/2"	2"
L	87	92	106	127	142
H	152	158	189	239	288
P	9.5	12.7	17.5	28.6	36.5
W	96	96	96	150	150
Weight (kg)	1.6	1.9	3	6.1	9.8

1500# - Socket Weld				
Size	1/2"	3/4"	1"	1 1/2"
L	92	106	127	142
H	158	189	239	288
P	9.5	12.7	17.5	28.6
W	96	96	150	150
Weight (kg)	2.2	3.5	7.5	11.6

2500# - Socket Weld			
Size	1/2"	3/4"	1"
L	106	127	142
H	189	239	288
P	7	12.5	15.5
W	96	150	150
Weight (kg)	4.1	8.4	13

(Code-AHV)



GATE VALVES - FORGED STEEL GATE VALVES - 150#, 300# & 600#



Welded Flange Ends

FLOWTORQ Forged Steel gate valves are manufactured with highest quality steel forgings. Forged form valves are used widely in high pressure applications in smaller sizes like 1/4" to 2" in ratings upto 4500#. Usually are manufactured in socket welded, threaded and welded flanged types as per client application requirement.

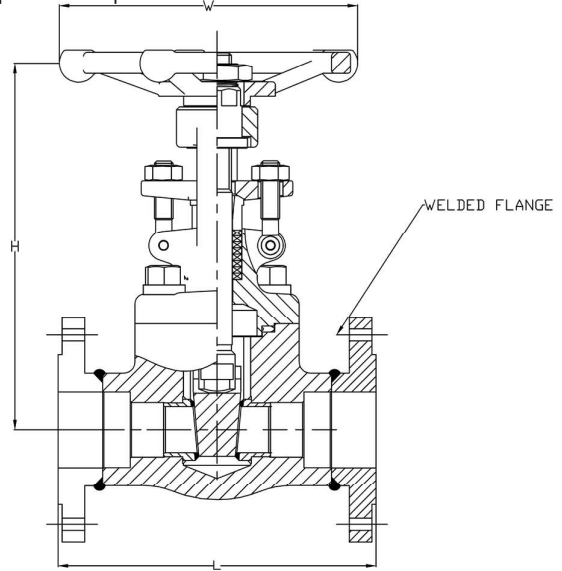

Design and Manufacturing Standard	API602
Testing Standard	API598
Face to Face Standard	ANSI B 16.11 / ANSI B 16.5
End Connections	NPT, Socket Weld / Flanged

150# - Welded Flange					
Size	1/2"	3/4"	1"	1 1/2"	2"
L	108	117	127	165	178
H	152	158	189	239	288
P	9.5	12.7	17.5	28.6	36.5
W	96	96	96	150	150
Weight (kg)	2.2	2.9	4.4	7.9	12

300# - Welded Flange					
Size	1/2"	3/4"	1"	1 1/2"	2"
L	140	152	165	190	216
H	152	158	189	239	288
P	9.5	12.7	17.5	28.6	36.5
W	96	96	96	150	150
Weight (kg)	2.4	3.1	4.6	8.1	12.2

600# - Welded Flange					
Size	1/2"	3/4"	1"	1 1/2"	2"
L	165	190	216	241	292
H	152	158	189	239	288
P	9.5	12.7	17.5	28.6	36.5
W	96	96	96	150	150
Weight (kg)	2.6	3.3	4.8	8.3	12.5

(Code-AHV)

